

# Model HD 1800 Hammer

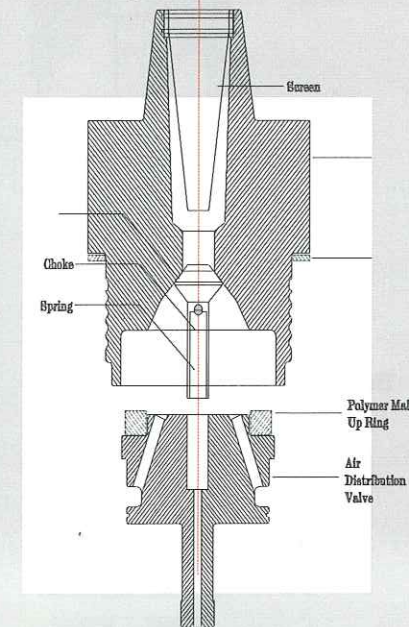

Designed to operate in all directions



High Quality  
Heavy Duty  
Shank HD 1800  
Wrench Dimples & Flats

Air Efficient  
Powerful

Hardened  
Porting  
Sleeve

**HOLTE**  
MANUFACTURING

# Model HD 1800 Specifications

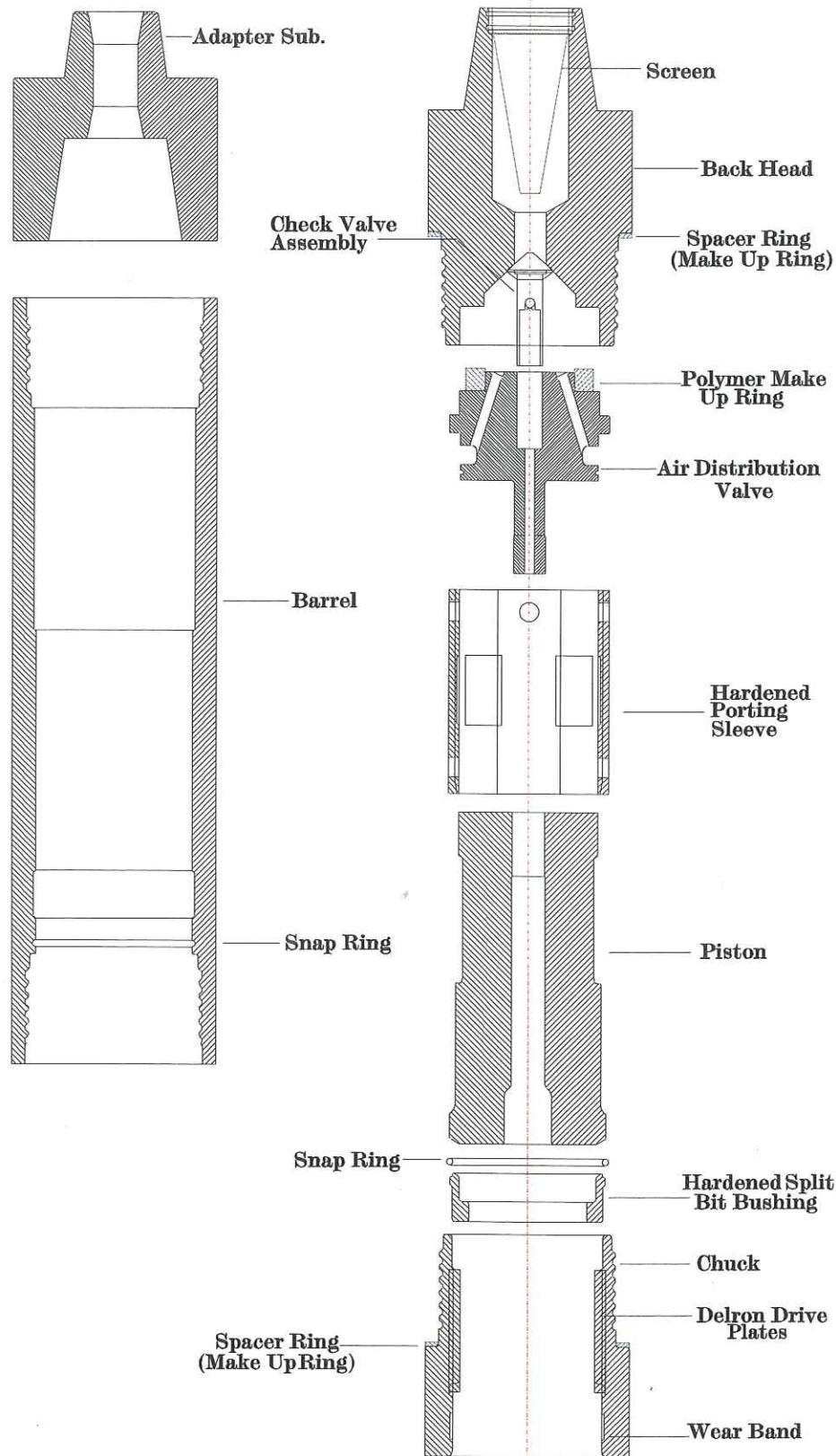

**Exploded Cross Section**

## Bits Available For HD1800

Bit sizes available for the HD1800 are,

URG Underreamer Style  
18in. to 24in.

Down Hole Bit Style  
18in. to 24in.

## Inside The HD1800

The patented split bit bushing, acts as a bit bearing and guide. This unique design requires no elastic band to hold it together during assembly. Most importantly, when revers rotation is required, the split bit bushing does not fall off if the chuck is accidentally unscrewed from the hammer.

The HD 1800 is designed with air porting that allows the hammer to operate efficiently in all directions.

Call Holte Mfg. today for more information

**(541)343-3399**

or e-mail us at  
[drilling@drilling.com](mailto:drilling@drilling.com)

or visit our web site at  
<http://www.drilling.com>

## Assembled Cross Section

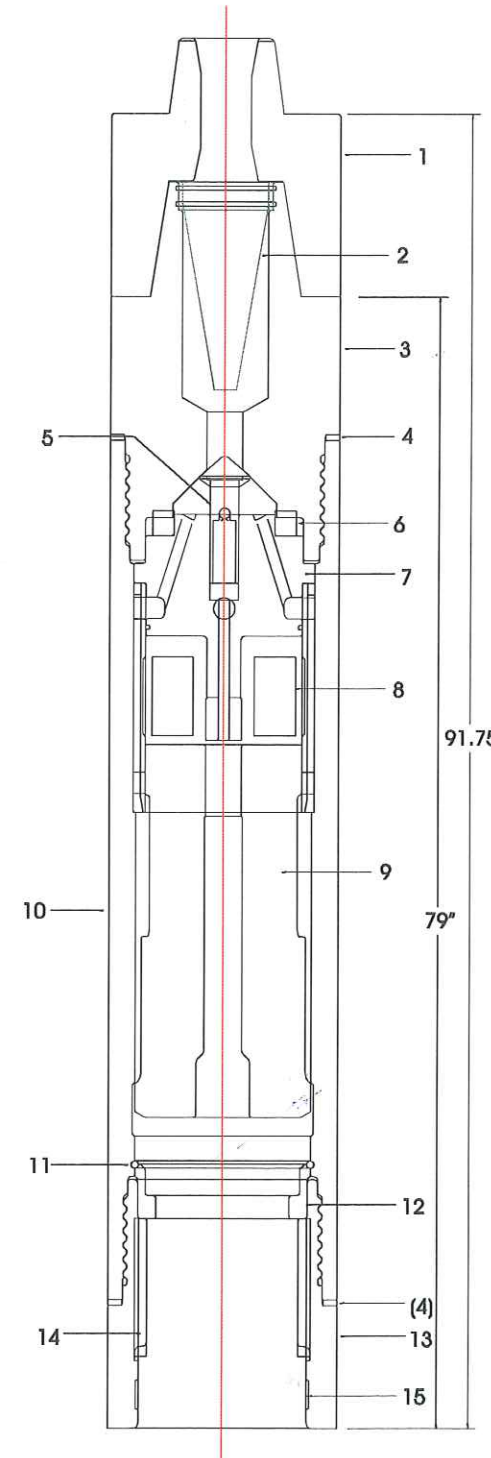

**HOLTE**  
MANUFACTURING

## Model 1800 Specification

Outside Diameter	16"	406mm
Tool Length w/Sub.	91-3/4"	2330mm
Total weight w/sub	4216lbs.	1916Kg
Piston Weight	680Lbs.	
Standard Shank	HD 1800 / N180	
Standard Top Sub.	8-5/8"	

## Air Consumption

C.F.M.	840	1050	1900
P.S.I.	125	160	250
Cycle Rate	450	600	800

## Parts List

No.	Qty.	PN#	Description
1	1	DHH1805	Adapter Sub
2	1	DHHS18	Screen (optional)
3	1	DHH1810	Back Head
4	2	DHH1815	Spacer Ring (make-up ring)
5	1	DHH1816	Check Valve Assembly
6	1	DHH1818	Polymer Make-Up Ring
7	1	DHH1820	Air Distribution Valve
8	1	DHH1830	Hardened Porting Sleeve
9	1	DHH1840	Piston
10	1	DHH1850	Barrel
11	1	DHH1855	Snap Ring
12	1	DHH1865	Split Bit Bushing
13	1	DHH1870	Chuck
14	12	DHH1875	Delron Drive Plates
15	1	DHH1880	Wear Band